

# TM848 Programmable Digital Timeswitch Instruction Manual

## PROGRAMMING INSTRUCTIONS

### 1. To Set or Change the Day and Time:

First clear the entire memory by pressing the **RESET** key. Then hold down the **CLOCK** key while pressing either the **DAY**, **HOURL** or **MINUTE** keys and continue pressing until the desired day or number is shown. Then simply lift finger off the **CLOCK** key to set.

### 2. To Set Program (ON/OFF Times):

Press **TIMER** key once to enter into program mode. Display will show "1 ON - - : - -"

Press **DAY** key to choose any of 15 different day combinations (see table below) for the first **ON** time. *Note: days of the week having the same program should be copied by selecting the desired combination of days.*

Press the **HOURL** key and then the **MINUTE** key to select the desired first **ON** time.

Press **TIMER** key once. Display will show "1 OFF - - : - -". Repeat previous step to select the desired first **OFF** time.

Repeat the entire sequence to complete up to eight total **ON/OFF** times as desired.

When programming is done, press the **CLOCK** key then the **MANUAL** key repeatedly until the indicator bar is above the word "AUTO"

### 3. To Review Program Settings:

Press **TIMER** key repeatedly. When done, press **CLOCK** key to return to the time of day.

### 4. To Cancel/Change Part of the Program:

Press **TIMER** key repeatedly until the particular **ON** or **OFF** time appears, then set new **ON** or **OFF** time. (See: 2. To Set Program)

### 5. To Override Automatic Operation:

Press **ON-AUTO-OFF** key to move indicator bar to the desired **ON** or **AUTO** or **OFF** position.

*Note: Timer will not resume automatic operation until indicator bar is repositioned above the word AUTO.*

From **ON** to **AUTO** mode, timer will remain **ON** until next **OFF** program

From **OFF** to **AUTO** mode, timer will remain **OFF** until next **ON** program

### 6. To Set Random Operation:

Press and hold **DAY** key and then press **MIN** key and symbol  $\mathcal{R}$  appears.

*Note: Random mode overrides all program settings and turns on and off randomly once every 10-120 minutes.*

Press and hold **DAY** key and then press **MIN** key to return to normal program mode.

This electronic 7-day timer has the capacity to accept up to 16 set points (8 ON and 8 OFF times) and can be set to repeat the daily program 15 different ways as the table below shows:

1	MON	TUE	WED	THU	FRI	SAT	SUN
2	MON						
3		TUE					
4			WED				
5				THU			
6					FRI		
7						SAT	
8							SUN
9	MON	TUE	WED	THU	FRI		
10						SAT	SUN
11	MON	TUE	WED	THU	FRI	SAT	
12	MON	TUE	WED				
13				THU	FRI	SAT	
14	MON		WED		FRI		
15		TUE		THU		SAT	

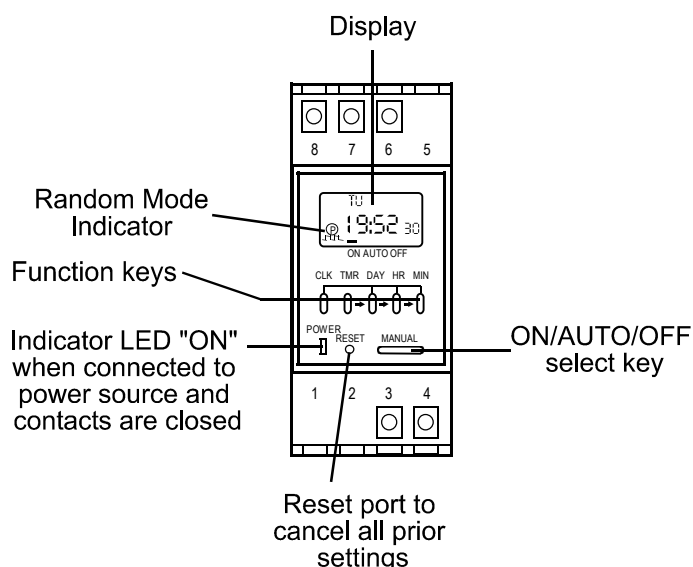

### Caution:

1. For voltage and electrical contact rating information, please refer to the label on the side of the timeswitch.
2. See label on the side of the timeswitch for correct wiring connections.
3. Press **RESET** key before first use to clear memory.
4. Timer may need to be connected to power source in order to program the time settings.