

ACUREV 2000

Multi-Circuits Networked Multifunction
Power Energy Meter



ISO9001 Certified



AcuRev 2000

Multi-Circuits Networked Multifunction Power and Energy Meter

- IEC and ANSI Revenue Grade Accuracy Measurement Standard
- Comply to IEC 62053-22 Measurement Standard
- Support up to 18 Individual Channels for Energy Measurement
- Advanced Power Quality Analysis for each Circuits
- Onboard Datalogging Enables Historical Trending Analysis
- Multiple communication ports and protocols for local and remote monitoring
- External and Built-in CT options provides perfect solution to Retrofit and New projects
- Extended Power Supply (100 - 415 Vac)
- Data (Pulse) Collection from Water and Gas Meter
- Built-In Serial, Ethernet and **NEW WiFi Communication**
- Modbus, HTTPs Webserver, HTTPs and FTP Data Post
- **NEW Free Cloud metering data storage**



DESCRIPTION

The AcuRev 2000 Series provides a compact and robust metering solution to multi-tenant submetering/billing and high density metering points applications. The unit performs real-time metering, measures energy consumption, multi-tariff time-of-use (TOU) and monitors power quality for 18 single phase circuits or 6 three phase circuits. The versatility of The AcuRev 2000 series meters are ideal for multi-tenants submetering such as office buildings, apartments, condominiums, shopping malls, data centers and other multiuser environments. Advanced communications options including Modbus via RS485, Modbus via ethernet, I/O, and infrared communications provide for extensive reliable data exchange.

The AcuRev 2000 series meters monitors up to 18 circuits/channels/tenants in a single unit. Multiple units can be connected together to meter unlimited number of circuits.

BENEFITS

The AcuRev 2000 series meters provide complete tenant sub-metering/billing and energy management solutions that benefit users by providing:

- Accurate energy reading for billing for multiple tenants
- Identify cost-saving opportunities by viewing the complete picture of energy usage, with detailed consumption historical trending data down to each circuits
- Identify high demand window and locate saving opportunities
- Verify utility bills to avoid overcharge by using revenue grade and accurate meters.

APPLICATIONS

- **Submetering in:**
 - Commercial Complex/Mall
 - Apartment/Condominiums
 - Hospitals/Public Services
 - Hotels/Office Buildings
 - Tenant Submetering/Billing
 - Data Centers
 - LEED Projects
- **Branch Circuits Monitoring**
- **Energy Management Systems**
- **Industrial and Utilities Applications**
- **Railway and Subway Systems**

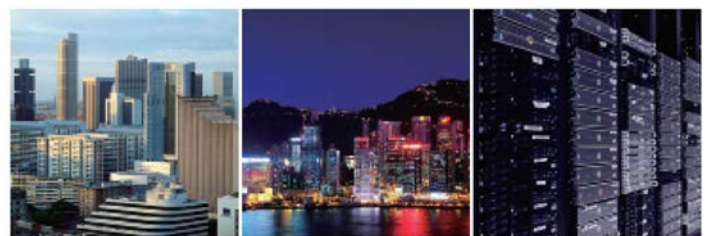

Variety of Flexible Installations and configurations for new and retrofit projects:

- 9 or 18 circuits input options so no circuits will be left empty
- Multiple current input and CT options:
 - AcuRev 2000 provides a built-in CT option where all CTs are built inside the meter, no external CT will be needed which is ideal for new projects
 - High accuracy, low cost split core 333mV CTs are supplied for simple clamp-on installation- no shoring block and power shutdown is needed during installation, which is ideal for retrofit projects
- Display can be either built-in or remote depending on the installation environment
- Direct voltage measurement of up to 690Vac L-L/400Vac L-N for electrical distribution systems
- Wide range in power supply thus no control transformer is required
- Built-in communication including ethernet enables simple connections with existing networks.

AcuRev 2000 Series Meter

Functions and measuring parameters for the two AcuRev 2000 series meters (AcuRev 2020 - multifunction energy meter) are listed below:

	Function	Parameter	AcuRev2020
ENERGY	Energy	Ep	●
	Reactive Energy	Eq	●
	Apparent Energy	Es	●
TIME OF USE	4 Tarrifs, 14 Schedules	TOU	●
POWER DEMAND	Power Demand	Demand_P	●
	Peak Power Demand	Demand_P_max	●
CURRENT DEMAND	Current Demand	Total and each circuit	●
	Peak Current Demand	Total and each circuit	●
REAL TIME METERING	Phase Voltage	V1,V2,V3	●
	Line Voltage	V12,V23,V31	●
	Current	Total and each circuit	●
	Power	Total and each circuit	●
	Reactive Power	Total and each circuit	●
	Apparent Power	Total and each circuit	●
	Power Factor	Total and each circuit	●
	Frequency	F	●
POWER QUALITY	Total Harmonic Distortion	THD	●
	Individual Harmonics	2nd ~ 31st (Voltage and Current)	●
	Current K Factor	KF	●
	Voltage Crest Factor	CF	●
	Voltage Unbalance	U_unbl	●
	Current Unbalance	I_unbl	●
TIME	Real Time Clock (Year, Month, Date, Hour, Minute, Second)		●
ALARMING	Over/Under Limit Alarming		●
DATA LOGGING	8MB Memory		●
COMMUNICATION PORT	Infrared		●
	RS485 Modbus(R)-RTU		●
	Ethernet Modbus(R)-TCP, HTTP, SMTP, SNTP		Option
	WiFi		●
I/O OPTION	2 Channel Pulse Output, Second Pulse, Demand Cycle		●
	8 Channel Digital Input with 15Vdc Power Supply		●
DISPLAY	Screen Display		●

FEATURES

Metering

- Energy: Active (kWh), reactive (kVAR) and apparent (kVA).
- Compliance with ANSI C 12.20 class 0.5; IEC62053-22 Class 0.5s
- Real-time RMS Metering: line and phase voltage, current for each circuit
- Power and Power Factor: Active (P), Reactive (Q), Apparent (S), Power Factor
- Demand and peak demand: Power and current demand for total and each circuits, 0-30 minutes window configurable.

Multi-tariff Time of Use (TOU)

TOU can be used according to different regional billing requirements. AcuRev 2000 series meters support up to 4 tariffs (sharp, peak, valley, normal), 14 schedules, 14 segments, weekends and 10-year holiday settings.

Data Logging

Energy, real-time metering, power quality and I/O data can be stored in the onboard, non-volatile memory.

E.g. capacity of onboard datalogging energy data is every 15 minutes for 3 phase system is 3.2 years.

Logged information can be retrieved via serial connection or remotely by ethernet as Excel, CSV or text format for historical trending and system analysis.

Over/Under Limit Alarms

Ten limit alarms can be assigned to various conditions. The alarming function effectively alarms and protects by sending out alarms such as light or buzzer and automatically shutting down equipments. For example, the alarm can be configured as peak demand, current or power quality.

Input/ Output (I/O)

AcuRev 2000 series meters are built with 8 digital inputs (DI), 4 relay outputs (RO) and 2 digital outputs (DO) to easily integrate other metering data and control in a single unit.

8 digital inputs: 8 dry contact inputs are designed to count pulses from water meter, gas meters and other devices with pulse output. This integration provides complete energy data to energy management and information reporting system. Digital inputs can also be configured to monitor switch status.

2 Digital Outputs: Two DOs can be used to send out pulses on energy data if energy management system requires pulse counting for data collection.

Power Quality Analysis

Power quality is essential to industrial and commercial electrical distribution system where monitoring and analyzing will help protecting the investment on sensitive equipments.

AcuRev 2000 series meters provides power quality parameters such as voltage and current THD, individual voltage and current harmonics up to 31st order, voltage crest factor, current K factor, voltage and current unbalance. These parameters are monitored real-time and logged in AcuRev 2000 series meters.

Communication Protocols

- Built-in Standard Modbus-RTU via RS485
- Modbus-TCP/IP
- FTP Post
- Ethernet
- HTTPs Webserver
- SMTP
- WIFI
- HTTP/HTTPs Post
- SNTP

Built-in secure and encrypted HTTPs Webserver provides reading and configuration access from any device



DIMENSIONS



Meter Base (with built-in display)

EM Module

DM Module

Remote Display

Type	Products
9 Circuits External CT Meter	Meter base (with built-in display)+ 1EM
18 Circuits External CT Meter	Meter base (with built-in display)+ 2EM
9 Circuits built-in CT Meter	Meter base (with built-in display)+ 1DM
18 Circuits built-in CT Meter	Meter base (with built-in display)+ 2DM
Remote Display	

Meter base(with built-in display)+ 1EM

Unit: mm (inch)

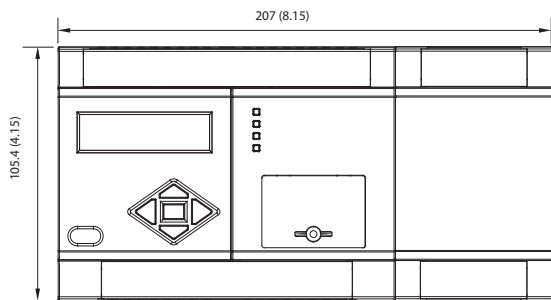

Front view

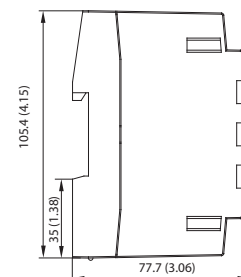

Side view

Meter base(with built-in display)+ 2EM

Unit: mm (inch)

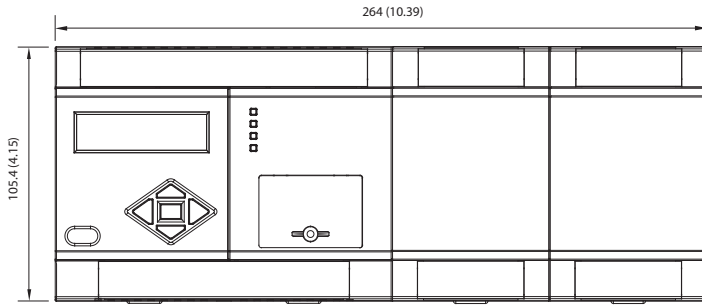

Front view

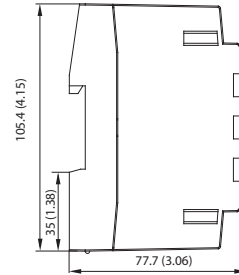

Side view

Meter base(with built-in display)+ 1DM

Unit: mm (inch)

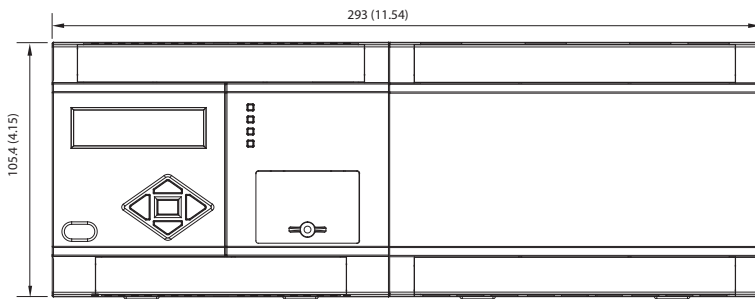

Front view

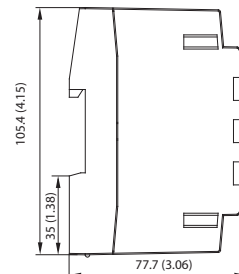

Side view

Meter base(with built-in display)+ 2DM

Unit: mm (inch)

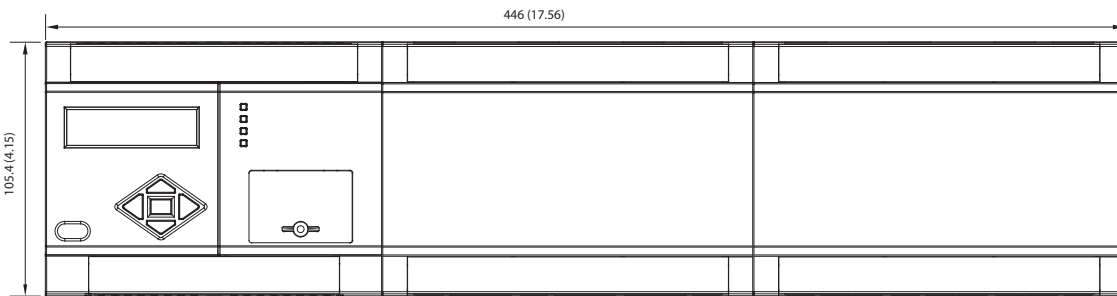

Front view

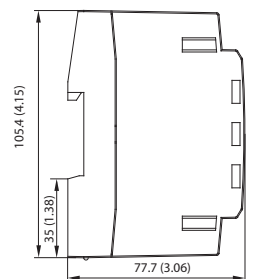

Side view

Display Module

Unit: mm (inch)

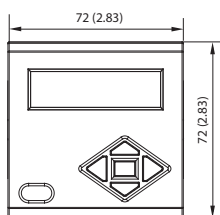

Front view

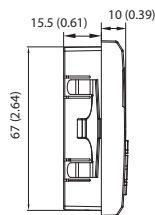

Side view

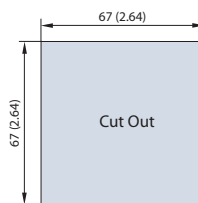

Cutout

Display Module is designed with flexibility in mind, it can be installed together with the base unit or can be mounted on a panel.*
 *(when ordered as a separate module. Please see ordering information for details).

Split core CTs

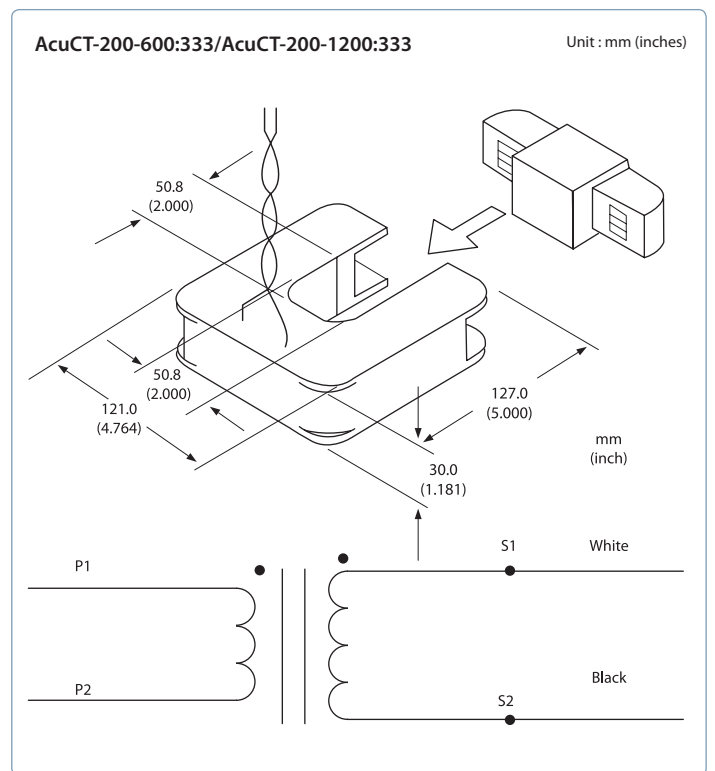
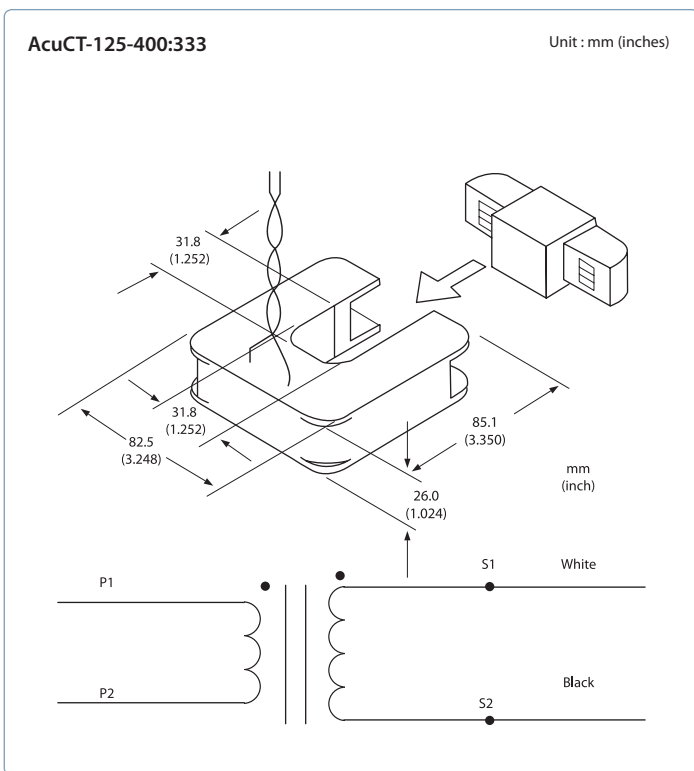
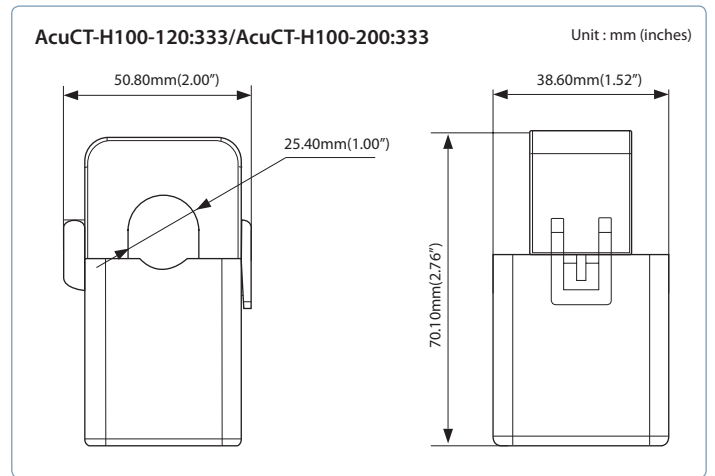
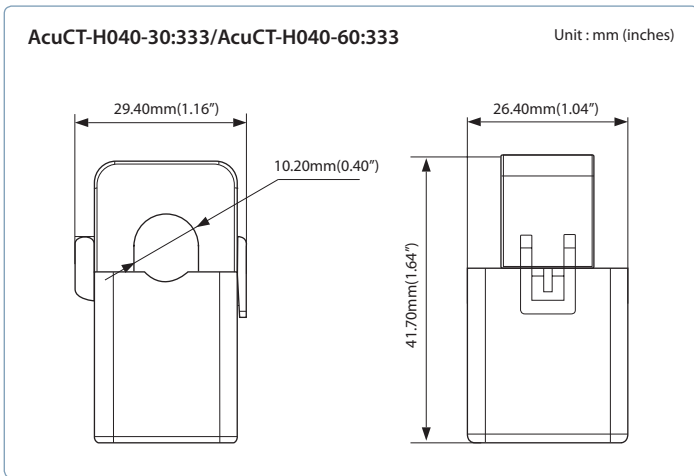

ROGOWSKI COIL

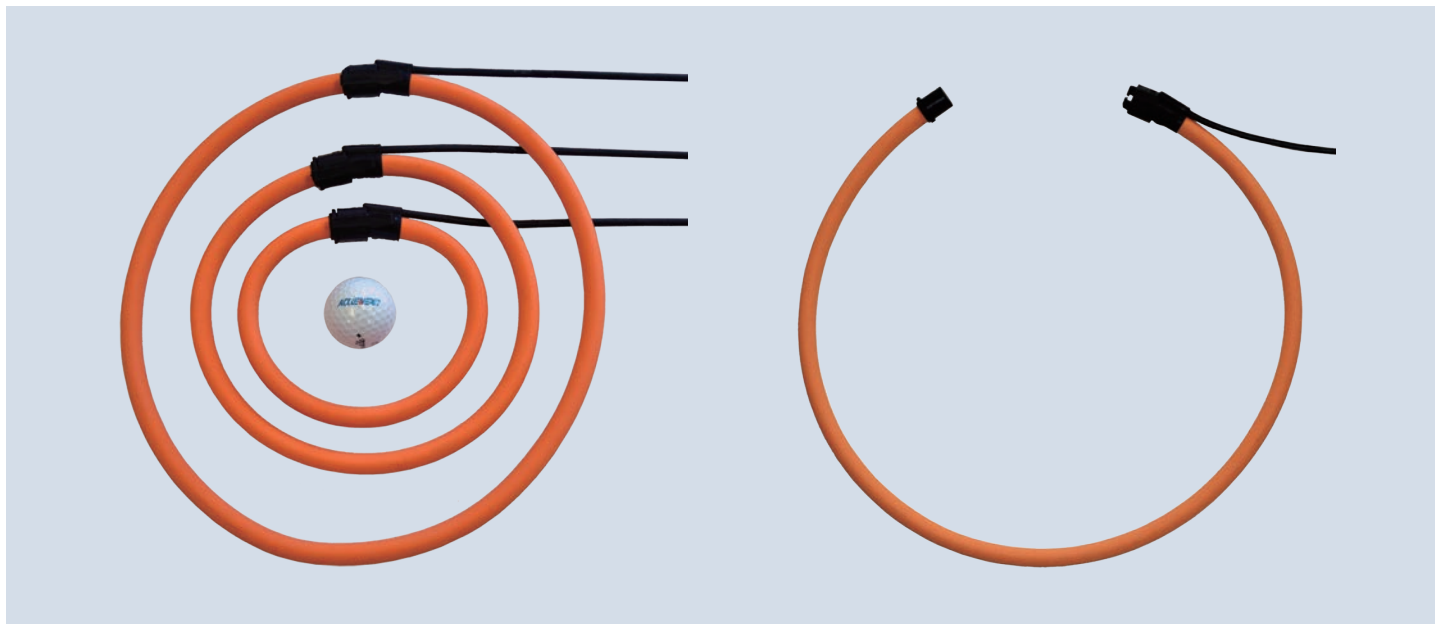

Accuenergy's flexible Rogowski coil is designed for use where regular solid or split core current transformers cannot fit, and is ideal for power quality monitoring such as harmonics. Advantages of the Rogowski coil include; high accuracy, wide measurement and frequency range with no additional integrator or power supply needed.

Specification	
Window Size	106mm (4.17"), 178mm (7.01"), 271mm (10.67"), 369mm (14.53")
Length of Coil	400mm (15.75"), 600mm (23.62"), 900mm (35.43"), 1200mm (47.24")
Current Input Ranges*	5A-1200A 12.5A-3000A 25A-6000A 50A-12000A 250A-50000A
Frequency Range	20Hz - 5kHz
Accuracy	0.5% at any point
Lead	White-Positive, Brown-Negative, Bare-Shield; 24AWG
Polarity	Arrow Towards Load (Current Flow Direction)
Operating Temperature	-20°C - 70°C
Temperature Drift	+/- 0.07% Within Operating Temperature Range
Material	Orange Thermoplastic Rubber, Flame Retardant UL 94 V-0 Rated
Dielectric Strength	7400Vac @ 50/60Hz for 1 Minute

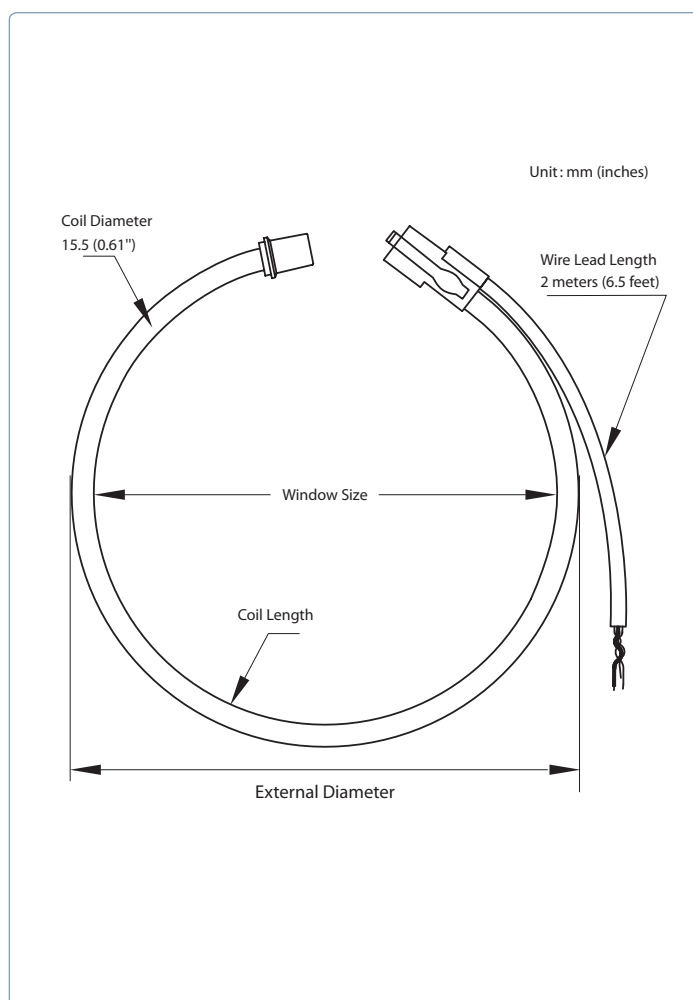

Dimensions mm (Inch)	RCT16	RCT24	RCT36	RCT47
Window Size	106 (4.17")	178 (7.01")	271 (10.67")	369 (14.53")
Coil Length	400mm (15.75")	600mm (23.62")	900mm (35.43")	1200mm (47.24")
External Diameter	143 (5.63")	207 (8.13")	302 (11.89")	398 (15.66")
Coil Diameter	15.5 (0.61")			
Wire Lead Length	2 meters (6.5 feet)			

*Note: Listed ranges are standard input ranges, for any other current input ranges please contact Accuenergy.

TYPICAL WIRING

External CT Mounting Wiring Diagram

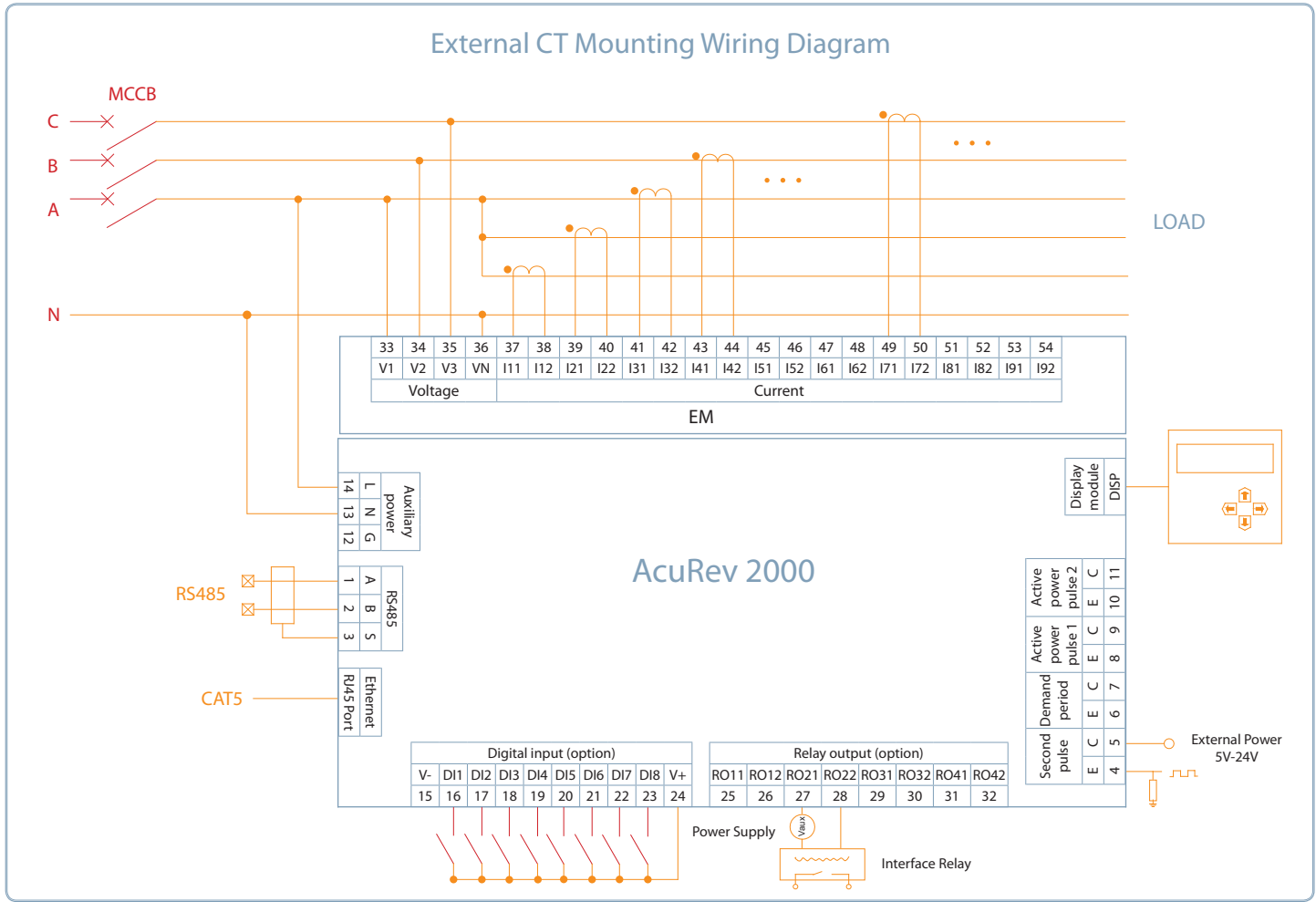

Direct Connection Wiring Diagram

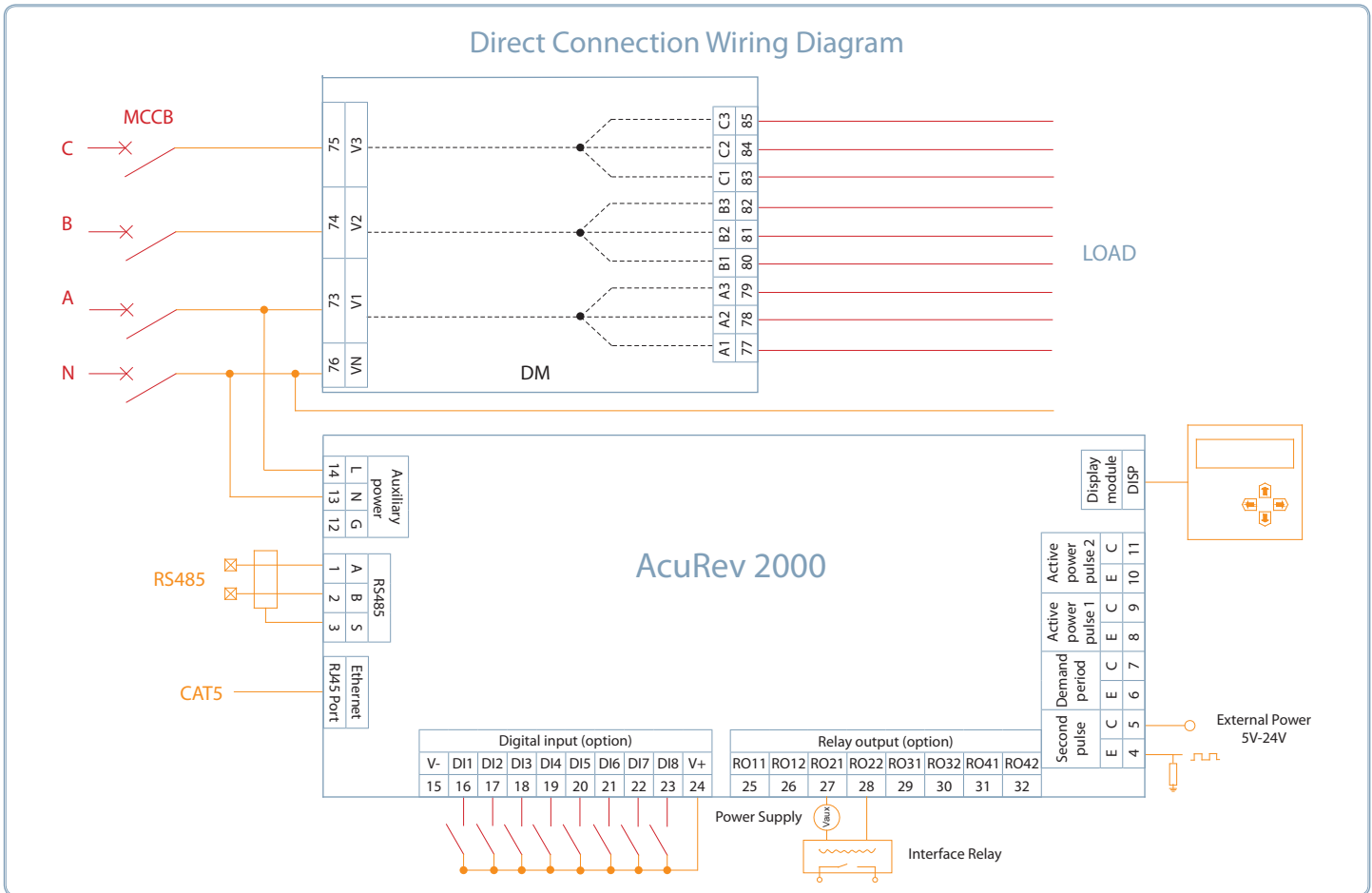

SPECIFICATIONS

MEASURE		
Parameter	Accuracy ± (%rdg)	Range
kWh	0.5s	0~999999.9kwh
V	0.5%	10~400V
I	0.5%	5mA~10000A
P	0.5%	4000.0kW
Q	0.5%	4000.0kvar
S	0.5%	4000.0kVA
PF	0.5%	-1.000~1.000
Freq	0.2%	45~65Hz
Activepower Demand	0.5%	4000.0kW
Current Demand	0.5%	5mA~10000A
Harmonic	1%	0~100%
Unbalance	1%	0~100%
Meter Running Time		0~999999.9 hours

INPUT	
Voltage Input	
Nominal Full Scale	400Vac L-N,690Vac L-L
Withstand	1500Vac continuous, 2500Vac, 50/60Hz for 1 minute
Input Impedance	2Mohm per phase
Metering Frequency	45Hz~65Hz
PT Burden	<0.2VA
Current Input (wired directly or through CT)	
External CT:	See ordering information.
Internal CT:	Each loop current limit: 20A-80A

MEASUREMENT STANDARD	
Measurement Standard	IEC 62053-22 (Class 0.5s) ANSI C12.20 (Class 0.2s)
Environment Standard	IEC 60068-2
Safety Standard	IEC 61010-1, UL 61010-1

ORDERING INFORMATION

AcuRev 2000	Model	Current Input	Communication option	Display
Ordering Number	-	-	-	-
Ordering Example	2020	2EM	WEB	D
	2020: Real-time Metering and advanced Power Quality datalogging meter	1EM: 9 circuits with external CT-333mV secondary input	Mod: RS485 only	D: Built-in Display
		2EM: 18 circuits with external CT-333mV secondary input	WEB: Ethernet, WIFI and RS485	E: External remote display
		1EM-RCT: 9 Circuits with flexible Rogowski coil input		
		2EM-RCT: 18 circuits with flexible Rogowski coil input		
		1DM: 9 circuits with 20-80A direct input		
		2DM: 18 circuits with 20-80A direct input		

Note: 1. Accuenergy suggests using USB-RS485 converter for configuration, and 3 CTs per three phase circuits.
2.All fields must be completed to create a part number.

Additional Accessories:

Communication converter: USB-RS485 (USB to RS485 converter)

Certificate of Calibration: Part #-NIST (Certificate of Calibration with NIST traceable test and calibration data)

Split core CT ordering information:

Part Number	Window Size (Diameter in inches)	Rated Input
AcuCT-H040-30:333	Hinged 0.4"	30A
AcuCT-H040-60:333	Hinged 0.4"	60A
AcuCT-H100-120:333	Hinged 1"	120A
AcuCT-H100-250:333	Hinged 1"	250A
AcuCT-125-400:333	Square 1.25"	400A
AcuCT-200-600:333	Square 2"	600A
AcuCT-200-1200:333	Square 2"	1200A

Note: Please contact Accuenergy if CTs in other sizes and ratios are needed.

IO	
Digital Input (DI)	
Input Style	Dry node
Input Current (MAX)	2mA
Input Voltage Range	15~30V
Start Voltage	12V
Stop Voltage	10V
Pulse Frequency (MAX)	100Hz, 50% Duty cycle
SOE Resolution	2ms

Auxiliary Power of DI	
Output Voltage	24VDC
Rated Power	1W

Digital Output (DO) (Photo-MOS)	
Voltage Range	0~250Vac/dc
Load Current	100mA (Max)
Output Frequency	25Hz, 50% Duty Ratio (20ms ON, 20ms OFF)
Isolation Voltage	2500Vac

OPERATING ENVIRONMENT	
Operation temperature	-25°C ~ 70°C
Storage temperature	-40°C ~ 85°C
Humidity	5%~95% non-condensing
Altitude	3000m

POWER SUPPLY	
Operating Range	100-415Vac, 50-60Hz; 100-300Vdc
Burden	10VA

ACCUEnergy

Accuenergy Corporation

Los Angeles-Toronto-Beijing

North America Toll Free: 1-877-721-8908

Web: www.accuenergy.com

Email: marketing@accuenergy.com

Revision Date: Aug., 2017 Document # 2012E1211

