



"Fit for purpose"
and world's best
practice in terms
of food safety

SmartCella

The essential solution for your small cold rooms

SmartCella can satisfy all needs in terms of features, installation, usability, expandability and flexibility with an essential but powerful solution.

Target applications are small cold rooms with basic requirements for:

- Restaurants
- Resorts
- Butchers
- Greengrocers

Smart solution

SmartCella is a smart and compact solution for the complete management of small single-phase cold rooms. It follows the logic of the ir33+ in terms of features, parameters and navigation, and benefits from the know-how and experience acquired with this product.

Easy to use

SmartCella is easy to use thanks to its user interface, with a touch keypad and large buttons. Installation is simplified thanks to DIN rail in the box for fast wall mounting and the already widely used ir33 DIN wiring diagrams.

Flexible and expandable

IP65 box is specifically designed for small cold room requirements: slim shape to be placed in the little space available, but still flexible to integrate additional components inside, such as:

- 3Hp relay
- Isolator, auxiliary terminal board
- Contactor

- Smart solution based on ir33+ logic and experience
- Intuitive user interface
- Flexible IP65 box ready for additional components
- Modbus and Carel protocols with auto-recognition
- DIN rail for fast wall mounting



SmartCella: just a few P/Ns with I/Os and features needed for target applications

Normal temperature cold rooms

1 output relay model





+3°C

output	inputs				
Relays	Sensors/Digital inputs				
Compressor	B1	B2	B3	B4	B5
 16 A, voltage free	NTC		NTC Digital inputs		

Low temperature cold rooms

4 output relays model

-18°C

output				inputs				
Relays				Sensors/Digital inputs				
Compressor	Defrost heaters	Evaporator fans	aux/light	B1	B2	B3	B4	B5
 2 HP, 230 Vac	 16 A, 230 Vac	 8 A, 230 Vac	 8 A, voltage free	NTC		NTC Digital inputs		

Flexible and expandable with additional contents

Model with free space to allow customers to add:

- External relays
- Contactors
- Auxiliary terminals



Dimensions (mm)

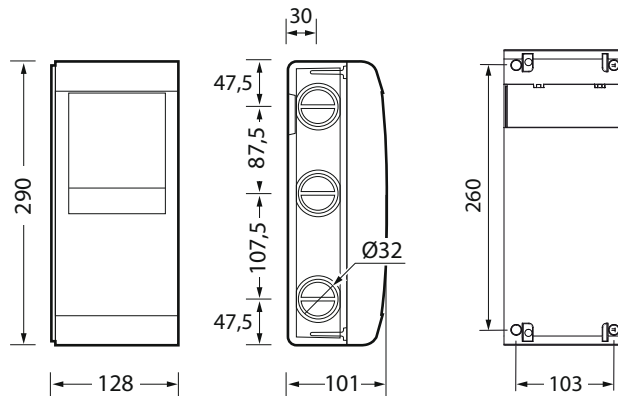

Product P/Ns

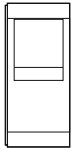
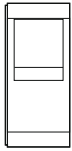
Size	P/N	Description
	WE00S1EN00	SmartCella 1 relay for NT cold rooms. Power supply 230 Vac, 16A compressor relay, 180° screw terminals
	WE00C2HN00	SmartCella 4 relays for LT cold rooms. Power supply 115/230 Vac, 2Hp compressor relay, 16A defrost relay, 8A fan relay, 8A auxiliary relay, 180° screw terminals



Easy to use

Thanks to touch keypad with large buttons, large and bright ir33+ display, and ir33+ logic



Easy to install

Thanks to DIN rail for fast wall mounting and standard ir33 DIN wiring diagrams



Flexible and expandable

Easy upgradable with additional components and expandable thanks to new modular mechanical system

Sales organization

SYDNEY HEAD OFFICE
CAREL Australia Pty Limited
 A.C.N. 067 528 269
 PO BOX 6809,
 Silverwater Bus Ctr N.S.W. 1811
 Unit 37, 11-21 Underwood Road
 Homebush N.S.W. 2140
 Tel. (+61) 2 - 8762 9200
 Fax (+61) 2 - 9764 6933
 e-mail: sales.au@carel.com
 www.carel.com.au

MELBOURNE OFFICE
 Suite 27 & 28 2nd Floor
 541 Blackburn Road
 Mt. Waverley VIC 3149
 PH: (+61) 03 9550 0898
 Fax (+61) 03 9550 0878
 e-mail: sales.au@carel.com

BRISBANE OFFICE
 Suite 28, Building 6
 2404 Logan Road
 Eight Mile Plains QLD 4113
 PH: (+61) 07 3340 5107
 Fax (+61) 07 3341 4390
 e-mail: sales.au@carel.com

EUROTEC Ltd
 750 Gt South Rd, Penrose
 Auckland 1061
 New Zealand
 Tel. (+64) 9 579 1990
 Fax (+64) 9 525 3334
 e-mail: sales@eurotec.co.nz