

Acuvim-L Series

Multifunction Power Meter



ISO9001 Certified



DESCRIPTION

The Acuvim-L series are multifunction power meters manufactured by Accuenergy. It is the ideal choice for monitoring and controlling of power distribution system. Some of the features and electric power parameters available on the Acuvim-L are:

- True-RMS Measuring Parameter
- 4-quadrant Energy
- Power Quality Analysis
- Over/Under Limit Alarm
- Energy Pulse Output
- TOU, 4 Tariffs, 12 Seasons, 14 Schedules

Acuvim-L may be used as a data gathering device for an intelligent Power Distribution System or a Plant Automation System. All monitoring data is available via digital RS485 communication port running Modbus® Protocol.

The quality of the power system is important with increasing use of electronic loads such as computers, ballasts or variable frequency drives. With the Acuvim-L power analysis option, any phase current or voltage can be displayed and the harmonic content calculated. By knowing the harmonic distribution, action can be taken to prevent overheated transformers, motors, capacitors, neutral wires and nuisance breaker trips. Redistribution of the system loading can also be determined.

APPLICATIONS

- Metering of distribution feeders, transformers, generators, capacitor banks and motors
- Medium and low voltage systems
- Commercial, industrial, utility
- Power quality analysis

FEATURES

Metering

- Voltage V1, V2, V3, V12, V23, V31
- Current I1, I2, I3, In
- Power P1, P2, P3, Psum
- Reactive Power Q1, Q2, Q3, Qsum

- Apparent Power S1, S2, S3, Ssum
- Frequency F
- Power Factor PF1, PF2, PF3, PF
- Energy Ep_imp, Ep_exp
- Reactive Energy Eq_imp, Eq_exp
- Apparent Energy Es
- Demand Dmd_I1, Dmd_I2, Dmd_I3, Dmd_P, Dmd_Q, Dmd_S

Monitoring

- Power Quality
- Voltage Harmonics 2nd to 15th and THD
- Current Harmonics 2nd to 15th and THD
- Voltage Unbalance Factor U_unbl
- Current Unbalance Factor I_unbl
- Max/Min Statistics
- Running Hour

Alarm

Two (2) parameter may be set within a specified time interval. If indicated parameter is over or under its setting limit and persists over the specified time interval, the event will be recorded with time stamps and trigger the alarm DO output. The indicated parameter can be selected from any of the 35 parameters available.

Pulse Output option

Two digital outputs can be configured as pulse output for kWh and kvarh. The pulse rate and width can be set.

Communication

RS485, industry standard Modbus® RTU protocol

Display

Clear and large character LCD Screen display with orange back light
Wide environmental temperature endurance

Outline

Small size 96x96x51 (92x92 cutout) DIN or 4" ANSI round

Acuvim-L Meter

Function		Parameter	AL	BL	CL	EL
REAL TIME METERING	Phase Voltage	U1, U2, U3	•	•	•	•
	Line Voltage	U12, U23, U31	•	•	•	•
	Current	I1, I2, I3, In	•	•	•	•
	Power	P1, P2, P3, Psum	•	•	•	•
	Reactive Power	Q1, Q2, Q3, Qsum	•	•	•	•
	Apparent Power	S1, S2, S3, Ssum	•	•	•	•
	Power Factor	PF1, PF2, PF3, PF	•	•	•	•
	Load Nature	L/C/R	•	•	•	•
ENERGY & DEMAND	Energy	Ep_imp, Ep_exp	•	•	•	•
	Reactive Energy	Eq_imp, Eq_exp	•	•	•	•
	Apparent Energy	Es	•	•	•	•
	Current Demand	Dmd_I1, Dmd_I2, Dmd_I3	•	•	•	•
	Power Demand	Dmd_Psum, Dmd_Qsum, Dmd_Ssum	•	•	•	•
TIME OF USE	Energy	TOU, 4 Tariffs, 12 Seasons, 14 Schedules				•
POWER QUALITY	Voltage Unbalance	U_unbl	•	•	•	•
	Current Unbalance	I_unbl	•	•	•	•
	Voltage THD	THD_V1, THD_V2, THD_V3	•	•	•	•
	Current THD	THD_I1, THD_I2, THD_I3	•	•	•	•
	Individual Harmonics	2 nd ~ 15 th (Voltage and Current)	•	•	•	•
STATISTICS	Max Current Demand	Dmd_I1_max, Dmd_I2_max, Dmd_I3_max	•	•	•	•
	Max Power Demand	Dmd_Psum_max, Dmd_Qsum_max, Dmd_Ssum_max	•	•	•	•
	Max & Min of Voltage		•	•	•	•
	Max & Min of Current		•	•	•	•
HOUR	Running Hour	Hour	•	•	•	•
I/O	Energy Pulse Output	2 DO, configured as pulse output for kWh and kvarh, the pulse rate and width can be set		•		
	Alarm Output			•		
COMMUNICATION	RS-485	Modbus®-RTU Protocol, 1200~38400 baud rate			•	•

Typical Wiring

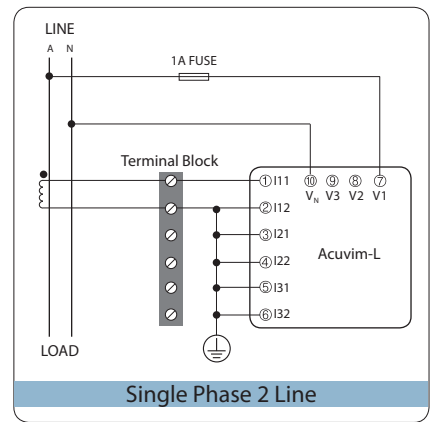
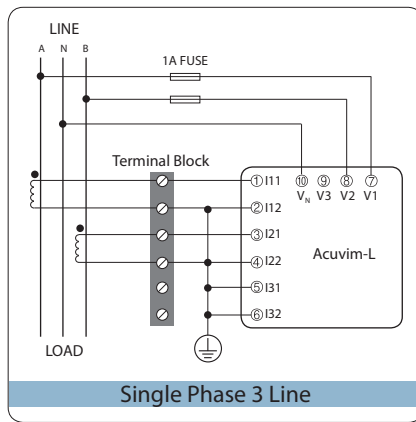
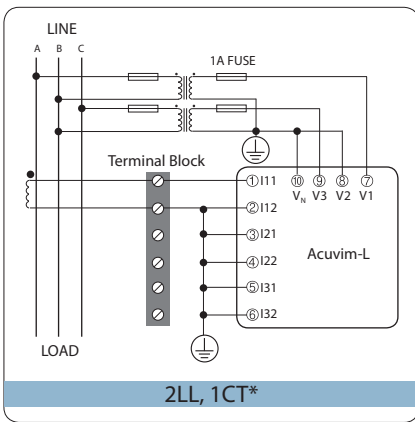
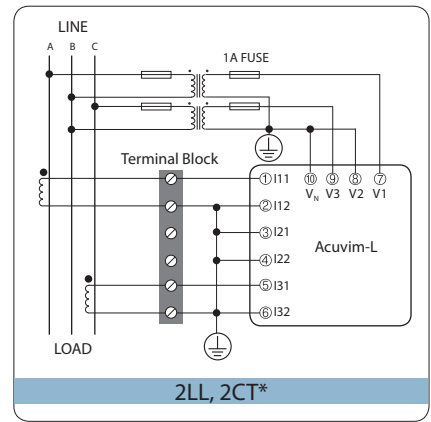
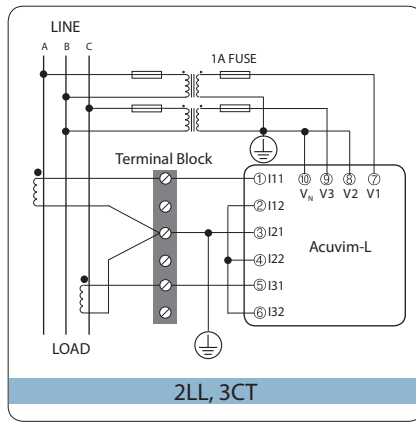
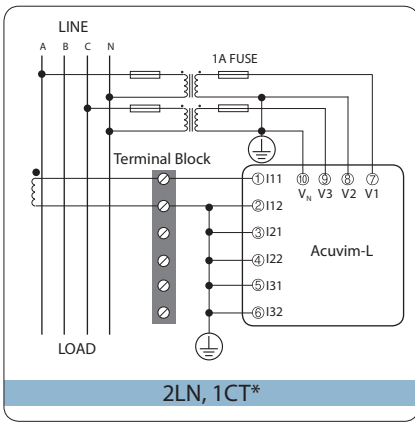
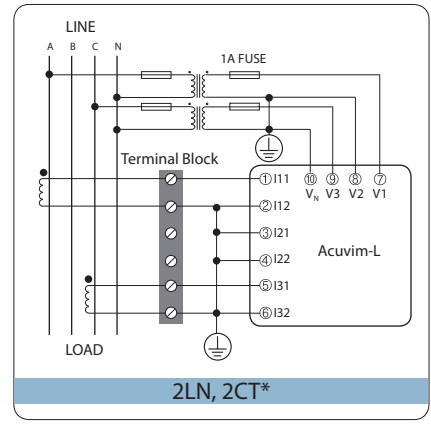
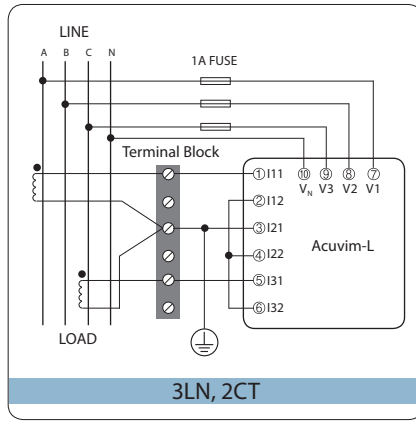
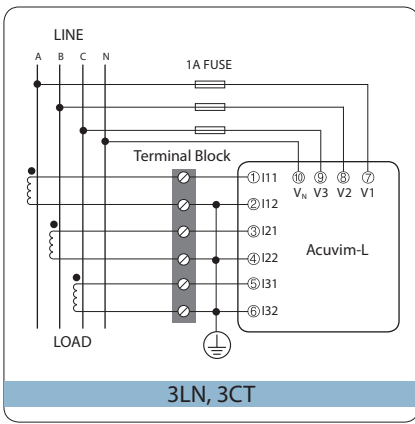

Note: "*" Wiring Diagram is not applicable to Acuvim-EL.

DIMENSIONS

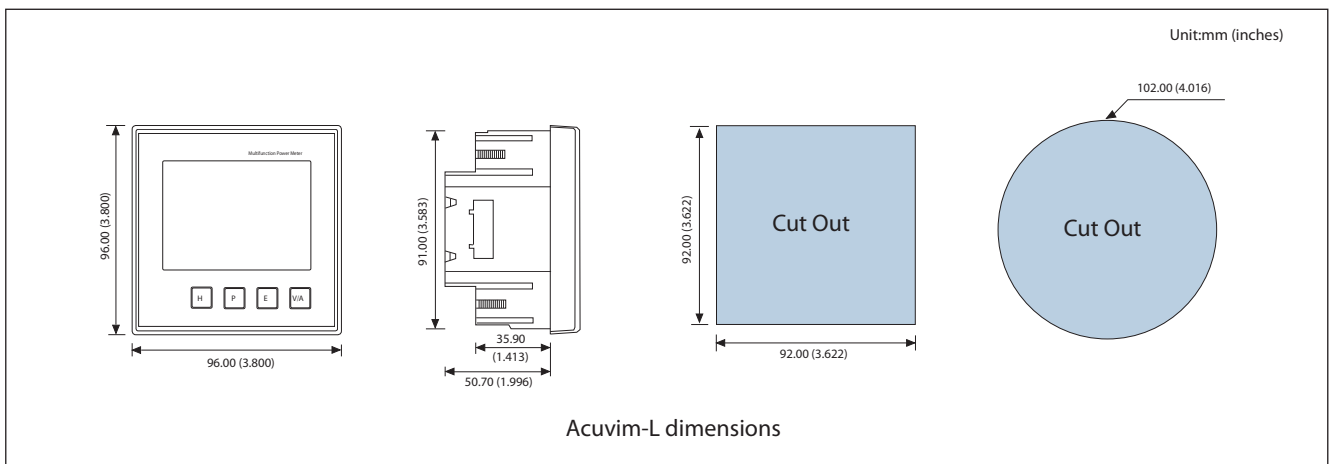

SPECIFICATIONS

METERING				
Parameters	Accuracy		Resolution	Range
	Acuvim-L	Acuvim-EL		
Voltage	0.5%	0.5%	0.1V	20V~500kV
Current	0.5%	0.5%	0.001A	0~50000A
Current Demand	0.5%	0.5%	0.001A	0~50000A
Power	1.0%	0.5%	1W	-9999MW~9999MW
Reactive Power	1.0%	0.5%	1var	-9999Mvar~9999Mvar
Apparent Power	1.0%	0.5%	1VA	0~9999MVA
Power Demand	1.0%	0.5%	1W	-9999MW~9999MW
Reactive Power Demand	1.0%	0.5%	1var	-9999Mvar~9999Mvar
Apparent Power Demand	1.0%	0.5%	1VA	0~9999MVA
Power Factor	0.5%	0.5%	0.001	-1.0~1.0
Frequency	0.2%	0.2%	0.01Hz	45~65Hz
Energy	1.0%	0.5%	0.1kWh	0~99999999.9kWh
Reactive Energy	1.0%	0.5%	0.1kvarh	0~99999999.9kvarh
Apparent Energy	1.0%	0.5%	0.1VAh	0~99999999.9kVAh
Harmonics	2.0%	—	0.01%	0~100.0%
Running Time			0.01hrs	0~99999999.9hrs

COMMUNICATION
RS-485 (Option)
Modbus®-RTU Protocol
2-wire connection, Half-duplex, Isolated
1200 to 38400 baud rate

INPUT	
Current Inputs (Each Channel)	
Nominal Current	5 A ac
Metering Range	0~6 A ac
Withstand	20Arms continuous
	100Arms for 1 second, non-recurring
Burden	0.05VA (typical) @ 5Arms
Pickup Current	0.1% of nominal
Accuracy	0.5%
Voltage Inputs (Each Channel)	
Nominal Full Scale	400Vac L-N, 690Vac L-L
Withstand	1500Vac continuous
	3250Vac, 50/60Hz for 1 minute
Input Impedance	2Mohm per phase
Metering Frequency	45Hz~65Hz
Pickup Voltage	10Vac
Accuracy	0.5%
Energy Accuracy (Acuvim-EL)	
Active (according to IEC 62053-22)	Class 0.5s
(according to ANSI C12.20)	Class 0.5
Reactive (according to IEC 62053-23)	Class 2
Harmonic Resolution	
Metered Value	2 nd ~15 th harmonics

CONTROL POWER	
Universal	AC or DC
AC/DC Control Power	
Operating Range	100~415Vac, 50/60Hz, 100~300Vdc
Burden	3W
Withstand	3250Vac, 50/60Hz for 1 minute
Low Voltage DC Control Power (Optional)	
Operating Range	20~60Vdc
Burden	3W

Digital Output OPTION	
Digital Output (DO)	(Photo-MOS)
Voltage Range	0~250Vac/dc
Load Current	100mA (Max)
Output Frequency	25Hz, 50% Duty Ratio (20ms ON, 20ms OFF)
Isolation Voltage	2500V

STANDARD COMPLIANCE	
Product	
USA	UL 61010-1
Canada	cUL 61010-1
Europe	IEC 61010-1
Emission	
Radiated/Conducted	FCC Part 15 Subpart B, Class A
Radiated/Conducted	EN 55011
Harmonic	IEC 61000-3-2
Voltage Fluctuation	IEC 61000-3-3
Radio Interference	EN 50081-2
Immunity	
Electromagnetic Compatibility	IEC 61000-6-2
ESD	IEC 61000-4-2
Radiated, radio-frequency, electromagnetic field	IEC 61000-4-3
Electrical fast transient/burst	IEC 61000-4-4
Surge	IEC 61000-4-5
Conducted disturbances	IEC 61000-4-6
Power frequency magnetic field	IEC 61000-4-8
Voltage dips and interruptions	IEC 61000-4-11
Generic Immunity Standard for Industrial Environment	EN 50082-2

OPERATING ENVIRONMENT	
Operation Temperature	- 25°C to 70°C
Storage Temperature	- 40°C to 85°C
Relative Humidity	5% to 95% non-condensing
Pollution Degree	2

ORDERING INFORMATION

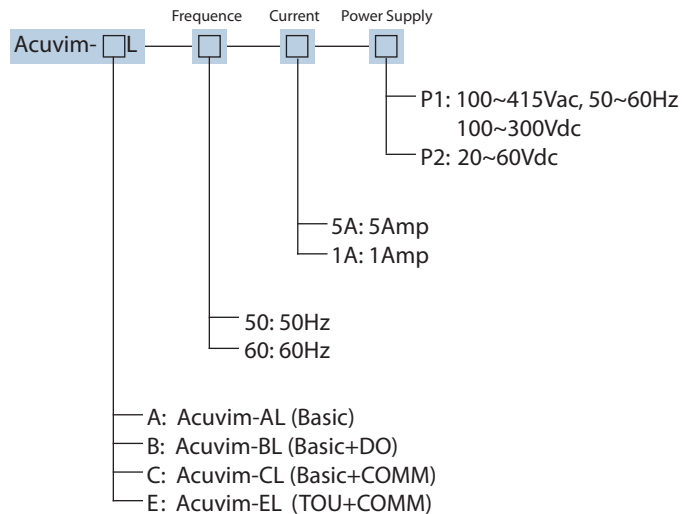

Acuvim-L Series Meter Ordering Example: Acuvim-EL - 60 - 5A - P1

ACCUENERGY

Accuenergy Corporation

Los Angeles-Toronto-Beijing

North America Toll Free: 1-877-721-8908

Web: www.accuenergy.com

Email: marketing@accuenergy.com

Revision Date: Oct, 2009

Document #1030E1102